

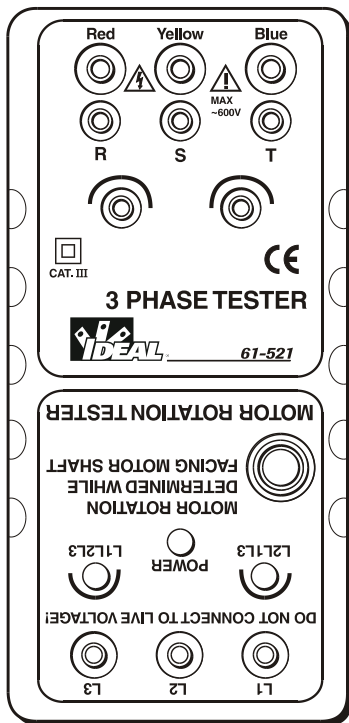

#61-521

3-Phase Tester & Motor Rotation Tester

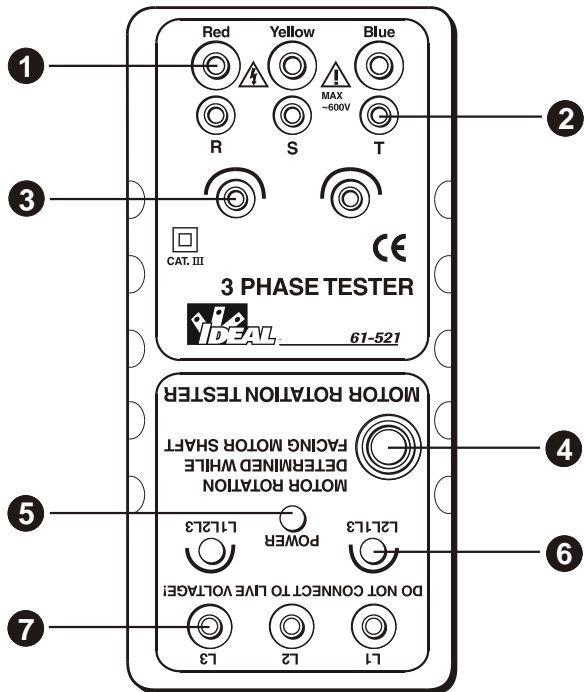



- (1) PHASE ROTATION INPUT TERMINAL
- (2) OPEN PHASE INDICATOR
- (3) PHASE ROTATION INDICATOR
- (4) MOTOR TESTER POWER SWITCH
- (5) MOTOR TESTER POWER INDICATOR
- (6) MOTOR ROTATION INDICATOR
- (7) MOTOR ROTATION INPUT TERMINAL

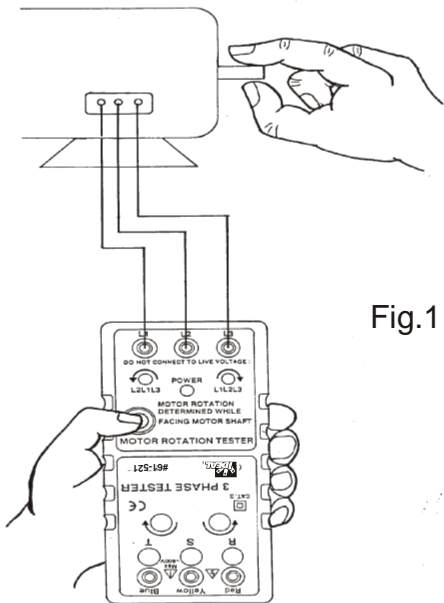
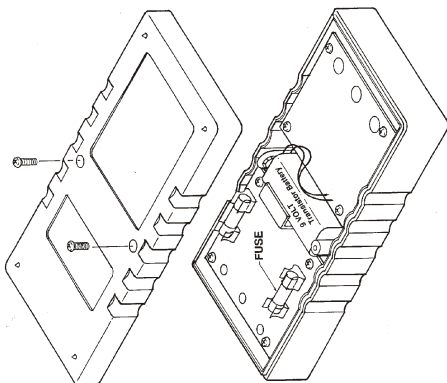

Fig.1

Fig.2



1. Introduction

NOTE

This meter has been designed and tested according to IEC Publication 348, Safety Requirements for Electronic Measuring Apparatus, IEC 1010 (En61010) and other safety standards.

Follow all warnings to ensure safe operation.

CAUTION

**READ "SAFETY NOTES" (NEXT PAGE)
BEFORE USING THE METER.**

2. Safety Notes

- Read the following safety information carefully before attempting to operate or service the meter.
- Use the meter only as specified in this manual; otherwise the protection provided by the meter may be impaired.
- Rated environmental conditions :
 - (1) Indoor use.
 - (2) Installation Category III.
 - (3) Pollution Degree 2.
 - (4) Altitude up to 2000 Meter.
 - (5) Relative Humidity 80% Max.
 - (6) Ambient Temperature 0~40°C.
- Observe the International Electrical Symbols listed below.



Meter is protected throughout by double insulation or reinforced insulation.



Warning ! Risk of electric shock.



Caution ! Refer to this manual before using the meter.



Alternating current.

3. Features

- Three functions in one unit, including open phase, phase sequence and motor rotation indication.
- This model is ideal for installing conveyor lines, pump systems and interconnected drivers.
- Identifies 3-phase sequence and open phase check.
- Battery operated.
- Meets IEC 1010(EN61010) safety requirements.
- Complete with three large alligator clips.

4. Measuring Methods

- Operation of 3-Phase Rotation Tester :
 - (1) Connect the test lead to 3-phase input terminals by R-S-T.
 - (2) Connect color alligator clips to the terminals of a 3- phase power source. Connecting order is optional.
 - (3) Make sure that all of the three lamps for open phase check are on. If so, there is no open phase. When any of the three lamps is not on, there is open phase.

Open phase
check lamp
"R" is not on



Open phase on
terminal where
RED alligator clip
is connected

Open phase
check lamp
"S" is not on



Open phase on
terminal where
YELLOW alligator
clip is connected

Open phase
check lamp
"T" is not on



Open phase on
terminal where
BLUE alligator
clip is connected

- (4) Check the rotating direction of the rotation indicator.

If the counter clockwise indicator is lit, alternate the connection two of the three alligator clips. When the clockwise indicator is lit and the power source terminals are connected by the RED, YELLOW and BLUE alligator clips, the phase sequence indicators (R, S and T) shall be lit respectively.

● Operation of Motor Rotation Tester :

- (1) Make sure there is no voltage present.
- (2) Connect the test leads to motor input terminals by L1-L2-L3, and press the power button (Fig1). The power indicator green lamp is lit. *(If the clockwise or counter clockwise red indicator is lit before rotating the motor shaft, it means voltage is present. Stop measuring. Take off the test leads and turn off the external power).* Rotate the motor shaft clockwise. If the clockwise indicator is lit, it means there is a 3-phase motor connection to the power supply by L1-L2-L3. The 3-phase motor should be rotated clockwise.
- (3) Connect the leads to 3-phase motor by L1-L2-L3, and press the power button. The power indicator green lamp is lit.

Rotate the motor shaft counter clockwise. If counter clockwise indicator is lit, it means there is a 3-phase motor connection to the power supply by L1-L2-L3. The 3-phase motor should be rotated clockwise.

- (4) If you require the motor to rotate counter clockwise, you should change the connection to L1-L2-L3. The motor should be rotated counter clockwise.

5. Specifications

Input Voltage : 100V AC up to 600V AC
max.

Frequency : 45 to 70 Hz.

Circuit Structure : All electronic (not
mechanical).

Power Requirement : 006P DC9V battery.

Power Consumption : Consumption current
approx. 14mA of motor
rotation field of tester.

AC power consumption
approx. 7mA per phase
rotation field of indicator.

Installation Category : IEC 1010 600V Cat. III.

Dimension : 153(L)x72(W)x35(D)mm.
(6.02x2.83x1.37 inch).

Weight : Approx. 182g
Included battery.

Accessories : Test Leads(red, yellow &
blue), Soft Vinyl Case,
Instruction Manual, Battery.

6. Maintenance

● Battery Replacement :

- (1) It is necessary to replace battery, when green lamp is dull lit.
- (2) Use a screwdriver to unscrew the screw on the back then open the case(Fig.2), remove the battery and replace with new battery (type 006P, DC9V).
- (3) Reinstall the case.

● Fuse Replacement :

- (1) It is necessary to replace fuse, when lamp indicator R or T show no connection, and change R-S-T is the same.
- (2) Use a screwdriver to unscrew the screws on the back then open the case(Fig.2), remove the broken fuse and replace with new fuse (200mA, 250V).
- (3) Reinstall the case.

● Cleaning and Storage :

WARNING

To avoid electrical shock or damage to the meter, do not get water inside the case.

Periodically wipe the case with a damp cloth and detergent. Do not use abrasives or solvents.

If the meter is not in use for periods of longer than 60 days, remove the battery and store them separately.

7. Warranty

This meter is warranted to the original purchaser against defects in material or workmanship for one year following the purchase of the tester. IDEAL INDUSTRIES, INC. will, at its option, replace or repair the defective unit, subject to verification of the defect or malfunction.

Warranty limited solely to repair or replacement; no warranty of merchantability, fitness for a particular purpose or consequential damages.

IDEAL INDUSTRIES, INC.

Sycamore, IL 60178, U.S.A.

800-304-3578 Customer Assistance

www.testersandmeters.com

ND 2869-1

Made in Taiwan